



400KG POWER HOIST 230V/1PH

MODEL NO: **PH400.V4**

Thank you for purchasing a Sealey product. Manufactured to a high standard, this product will, if used according to these instructions, and properly maintained, give you years of trouble free performance.

IMPORTANT: PLEASE READ THESE INSTRUCTIONS CAREFULLY. NOTE THE SAFE OPERATIONAL REQUIREMENTS, WARNINGS & CAUTIONS. USE THE PRODUCT CORRECTLY AND WITH CARE FOR THE PURPOSE FOR WHICH IT IS INTENDED. FAILURE TO DO SO MAY CAUSE DAMAGE AND/OR PERSONAL INJURY AND WILL INVALIDATE THE WARRANTY. KEEP THESE INSTRUCTIONS SAFE FOR FUTURE USE.



Refer to instructions



Wear protective gloves



Wear safety footwear



Indoor use only



Wear head protection

1. SAFETY

- ✓ The substance of the below shall be included in the instructions:
- ✓ The user shall ensure that the operating personnel are given the necessary training.
- ✓ The operator shall always work in compliance with the operating instructions.
- ✓ Keep instructions in a safe place for future use.
- 1.1. ELECTRICAL SAFETY**
- WARNING!** It is the user's responsibility to check the following:
 - ✓ Check all electrical equipment and appliances to ensure that they are safe before using.
 - ✓ Inspect power supply leads, plugs and all electrical connections for wear and damage.
 - ✓ Ensure that the insulation on all cables and on the appliance is safe before connecting it to the power supply.
 - * **DO NOT** use worn or damaged cables, plugs or connectors.
 - ✓ Ensure that any faulty item is repaired or replaced immediately by a Sealey qualified technician.
 - ✓ If the cable or plug is damaged during use, switch off the electricity supply and remove from use.
 - ✓ Sealey recommend that an RCD (Residual Current Device) is used with all electrical products.
- Important:** Ensure that the voltage rating on the appliance suits the power supply to be used and that the plug is fitted with the correct fuse.
- * **DO NOT** pull or carry the appliance by the power cable.
- * **DO NOT** pull the plug from the socket by the cable.
- 1.2. GENERAL SAFETY**
- WARNING!** Ensure Health & Safety, local authority, and general workshop practice regulations are adhered to when using this equipment.
 - ✓ Familiarise yourself with the application, limitations and potential hazards of the hoist.
 - ✓ The operator shall always work in compliance with the operating instructions.
 - ✓ The operator shall lift the load from the ground with the minimum speed available at the hoist. The rope shall be tightened and shall not be in the slack-condition when the load is being lifted from the ground.
 - ✓ The hoist is not designed to lift loads above the rated capacity of the hoist.
 - * **DO NOT** try to lift fixed or obstructed loads. **DO NOT** side-pull loads.
 - * Excessive inching (e.g. giving short pulses to the motor) shall be avoided.
 - * The hoist is not designed for lifting of persons.
- WARNING!** Disconnect the hoist from the mains power before changing accessories, servicing or performing any maintenance.
 - ✓ Maintain the hoist in good condition (use an authorised service agent).
 - ✓ Always check that the mains voltage is identical to the voltage quoted on the rating plate. In the event that the mains voltage is not suitable, it may cause the machine to work abnormally and thus result in personal injury.
 - ✓ Replace or repair damaged parts. Use genuine parts only. Unauthorised parts may be dangerous and will invalidate the warranty.
 - ✓ Locate hoist in a suitable work area, keep area clean and tidy and free from unrelated materials. Ensure that there is adequate lighting.
- WARNING!** Ensure that the mounting for the hoist is capable of supporting the rated capacity of the hoist (plus the weight of the hoist) without failure and that the hoist is mounted horizontally.
 - ✓ Protect yourself from electrical shock. Avoid physical contact with grounded surfaces (e.g. pipes, heat radiators, stoves or refrigerators).
 - ✓ Keep the hoist clean for best and safest performance and check moving parts alignment regularly.
 - ✓ Remove ill fitting clothing. Remove ties, watches, rings and other loose jewellery and contain and/or tie back long hair.
 - ✓ Keep children and unauthorised persons away from the work area.
 - ✓ Ensure the load is correctly secured before operating the hoist.
 - ✓ Always wear safety equipment (such as rubber gloves, non-slip footwear, hearing and hair protection and etc.) when working.
 - ✓ Keep hands away from the cable reel when winding the hoist in.
 - * **DO NOT** use the hoist for any purpose other than that for which it is designed.
 - * **DO NOT** operate the hoist if any parts are damaged or missing as this may cause failure and/or possible personal injury.
 - * **DO NOT** exceed the rated capacity of the hoist, see data plate.
 - * **DO NOT** use two or more machines to lift the same object.
 - * **DO NOT** adjust or tamper with the maximum lift cut-out mechanism.
 - * **DO NOT** use the hoist out of doors. Indoor use only.
 - * **DO NOT** get the hoist wet or use in damp or wet locations or areas where there is condensation.
 - * **DO NOT** allow untrained persons to operate the hoist.

- ✗ **DO NOT** operate the hoist when you are tired or under the influence of alcohol, drugs or intoxicating medication.
- ✗ **DO NOT** use the hoist where there are flammable liquids, solids or gases such as paint solvents, etc.
- ✗ **DO NOT** attempt to lift angled loads or to drag loads with the hoist. The centre of gravity of the load must always be directly below the hoist.
- ✗ **DO NOT** allow the load to swing beneath the hoist.
- ✗ **DO NOT** allow a raised and supported load to fall and thus shock load the mounting, hoist, cable and hook.
- ✗ **DO NOT** use more than one hoist to lift a load.
- ✗ **DO NOT** leave the hoist unattended with a suspended load.
- ✗ **DO NOT** leave the load hanging in the air long-term, to prevent the deformation of the pieces.
- ✓ While the machine is in operation do not carry out any repairs or inspections.
- ✗ **DO NOT** work or stand under a hoisted load.
- ✗ **DO NOT** wrap the hoist cable around the load.
- ✓ Prohibit unwanted start-ups on loose steel rope.
- ✓ Be sure to hoist the loads with lowest speed from the ground. The cable should be tense but not unwound when start loading from the ground.
- ✓ Pull out the plug when the cable hoist is not in use.
- ✗ **DO NOT** use the hoist to lift dangerous materials. It is prohibited to transport hot, molten masses.
- ✓ Use a qualified person to lubricate and maintain the hoist.
- ✓ When not in use and before carrying out repairs/maintenance isolate the hoist from the power supply.
- ▲ **DANGER!** If the red indicator mark is visible when unwinding the cable, please stop the cable winch immediately and do not continue to unwind the cable!
NOTE: When replace the wire rope, be sure to pull rope into the square hole of rope drum, and then pull it out from the round hole. With that wind the rope two circles and then pull it to the baffle which is side of rope drum and fix it.
- ✓ Always wind the cable as shown in the image in fig.8
- ✓ Ensure that the hook moves in the same direction as shown on the control switch.
- ✓ The end switch (Automatic stop mechanism lever) is not allowed to be used as an off -switch or be dismantled, which is a safety device to prevent that the weight is lifted over the boundary.
- ✓ Check the cable hoist at regular intervals for signs of damage. The control switch must be in good condition.
- ✓ Store the cable winch in a proper manner when it is not in use. Store the machine at a dry, high or lockable place, out of the reach of children.
- ✓ Have repair and service work carried out only by authorised workshops by a trained persons.
- ✓ Always concentrate fully when operating the cable hoist.
- ✓ Depending on the frequency of use, after 20 hours of continuous operation, the machine must be taken in for a thorough maintenance (at least once a year).
- ✓ If the brakes stop functioning and the load lowers quickly, one should press the Off-switch immediately and then the On-switch. After unloading, please send the machine to a qualified professional for repairs.

2. INTRODUCTION

Approved to EU and UK Lifting Gear Regulations. Fitted with a powerful 750W motor with a thermal overload switch. Due to the remote control, the hoist can be operated easily, and from a safe distance. Fitted with an automatic system to stop the unit at it's full lift height. Two mounting brackets are included, to easily install the hoist to a suitable support arm. (The support bar is not included).

3. SPECIFICATION & CONTENTS

Model No:	PH400.V4
Capacity (Double Cable):	400kg
Capacity (Single Cable):	200kg
Current:	3.3A
Dimensions W x Length:	147mm x 360mm
Duty Cycle:	S3
Fuse Rating:	10A
Group of Mechanisms:	M1
Insulating Grade:	B
IP Rating:	IP54
Lift Height (Double Cable):	6m
Lift Height (Single Cable):	12m
Lift Speed (Maximum):	8m/min
Load current:	3.1A
Minimum Rope Tensile Strength:	1770N/mm ²
Motor Power:	750W
Nett Weight:	32.5kg
Plug Type:	3-Pin

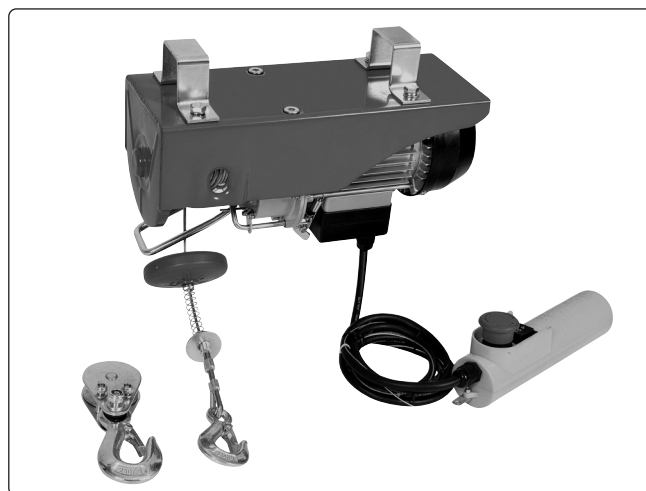

Power Supply Cable Length:	1.3m
Permitted voltage drops:	208V
Peak current:	2-3 Times Load Current
Rope Diameter:	Ø3.8mm
Operating Temperature Limits:	0 to +40°C
Voltage:	230V~50Hz
Load current:	3.1A

4. FEATURES

1	Fastening clamps
2	Fastening hole for hook
3	Drum
4	Lever for maximum cable length
5	Automatic stop mechanism lever
6	Steel cable
7	Cut-out weight
8	Load Hook
9	Emergency Stop switch
10	Push button
11	Remote control
12	Power cable
13	Control cable
14	Motor
15	Pulley

5. PROPER USE

The cable hoist is designed for lifting and lowering loads in enclosed areas commensurate with the machine's capacity.

The equipment is to be used only for its prescribed purpose. Any other use is deemed to be a case of misuse. The user / operator and not the manufacturer will be liable for any damage or injuries of any kind caused as a result of this.

Please note that our equipment has not been designed for use in commercial, trade or industrial applications.

Warranty will be voided if the machine is used in commercial, trade or industrial businesses or for equivalent purposes.

6. BEFORE USE

- 6.1. Before you connect the equipment to the mains supply make sure that the data on the rating plate are identical to the mains data. Always pull out the power plug before making adjustments to the equipment.
- 6.2. Please make no-loading test before start-up operation at first, and please check:
A: The operation of up/down operating switch to insure the controlling of the hoisting and lowering of load hook.
B: The operation of up limit bracket to make sure the cut-off of circuit.
C: The operation of down limit bracket to make sure the cut-off circuit when the steel cable is nearly used up.
D: Any abnormal sounds when starting operation.
E: The steel rope is possibly damaged (split or bent), or reaching 20 hours of use: change the rope immediately.
- 6.3. The cable hoist is not suitable for transporting hot and/or molten masses and in addition it is not suitable for use at low temperatures or in aggressive atmospheres.
- 6.4. It is in mechanical group M1.
- 6.5. Read and digest the operating instructions before you use the cable hoist. Ensure that the operator knows how the machine works and how it should be operated. The user should always operate as set out in the operating instructions. It is strongly recommended that two persons install the cable hoist, as it is heavy.
- 6.6. The cable hoist is not designed for continuous operation. Its mode of operation is:
Intermittent mode without influencing the starting process.
The rated capacity of the machine does not vary due to the position of the load.
- 6.7. Please inspect the hook before operation is possible damaged or distortion replace it.
- 6.8. The service life of the cable hoist is approximately 8000 cycles (excluding wearing parts). When the hoist has completed 8000 cycles, all its mechanical parts must be checked and overhauled.
- 6.9. Operation using a residual current protective device (Red Emergency Stop Switch) offers additional protection under danger and in emergency circumstances. Then screw the emergency shut off switch head in the arrow direction to recover operation, after rectifying the problem.
- 6.10. Make sure there is enough lubricant on parts. Daub the lubricant on the load hook, cable drum shaft, gear box, and bearing every 6 months.
- 6.11. **UNPACKING**
- 6.12. After opening the packaging, inspect the frame, the steel cable, the hook and the electric control mechanism for signs of possible transit damage.

7. ASSEMBLY & INSTALLATION

- 7.1. The cable hoist is fitted with two fastening clamps with which it has to be fastened to a rectangular tube. The dimensions of the tube must conform with the size of the fastening clamps and must be capable of supporting twice the rated load. We recommend that you seek advice from a qualified technician, see fig's 1 & 2.
- 7.2. All screws must be tightened correctly. A qualified technician should check the anchoring of the tube before the machine is started.
A) Install the machine on a steel beam. Use only the enclosed installation brackets which can be attached to the top of the mounting casing using the screws, washers, and spring washers.
The steel beam must be able to withstand at least double the rated lifting capacity of the cable hoist.

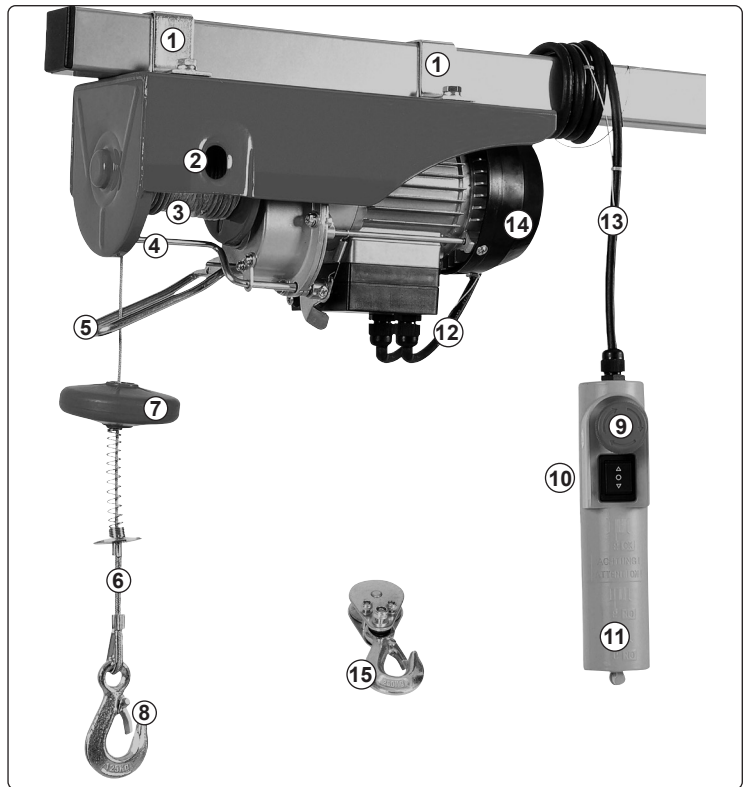

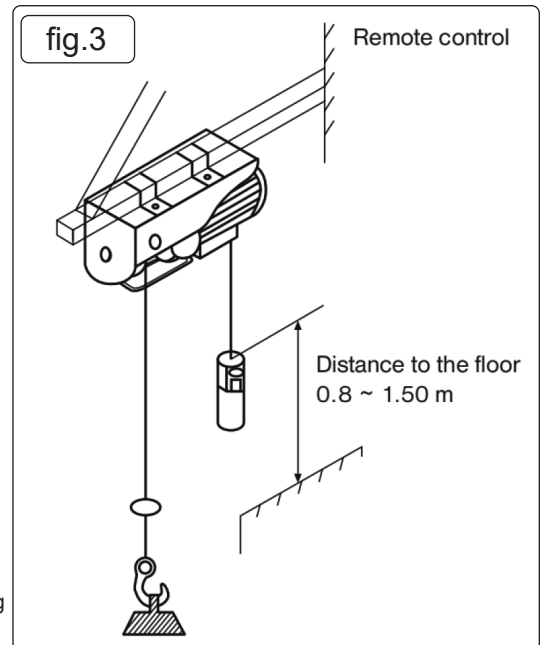
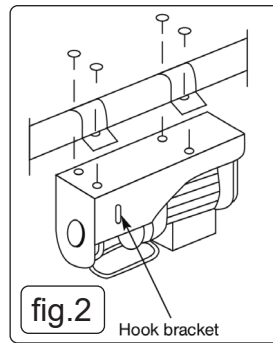
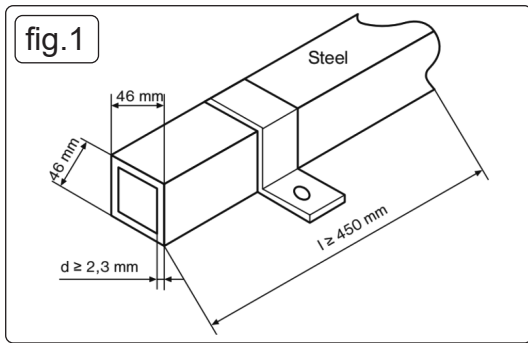

B) The steel beam must have a diameter of 46x46 mm, a wall thickness of at least 2.3 mm and a length of at least 450 mm.

C) The steel beam must be securely anchored in a wall. The anchor must be installed correspondingly sturdy in order to be able to withstand the load.

D) Ensure that the cable hoist is installed level and not slanted.

E) The remote control must be easily accessible at all times and must therefore be installed at a distance to be the floor of between 0.8m and 1.5m, fig.3.

F) Insert the load hook into the hook bracket of the mounting casing when using the additional load hook with deviating shaft.

7.3. BLOCK AND TACKLE FUNCTION

7.3.1. The cable hoist is fitted with a return roller (15) and an additional hook (16). If these parts are used correctly, the cable hoist can lift twice its rated load.

7.3.2. Fit the return roller (15) and additional hook (16) as shown in Fig's 4-6. The permanent hook (8) must be attached to the fastening hole (2) (Fig. 6).

The load is now raised by two steel cables, which means that the cable hoist can lift twice its rated load, fig.7.

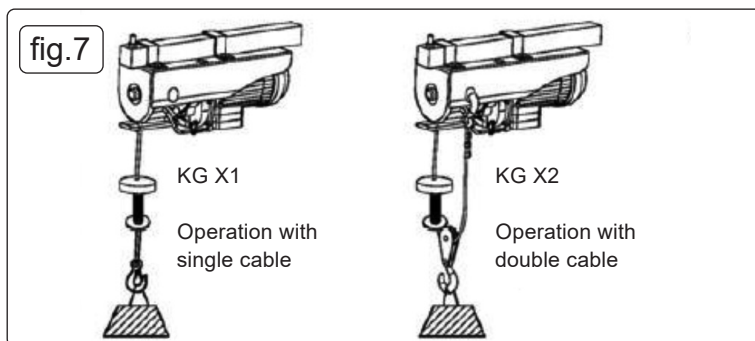
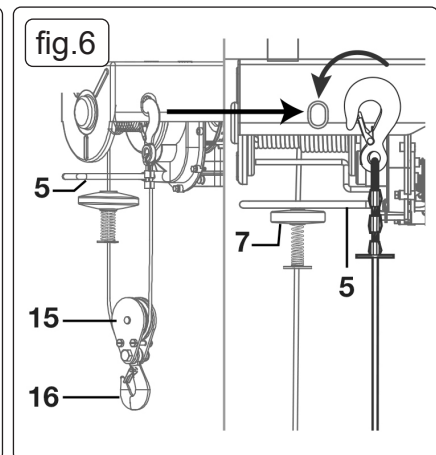
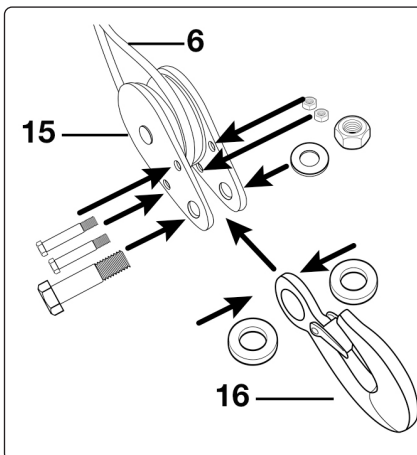
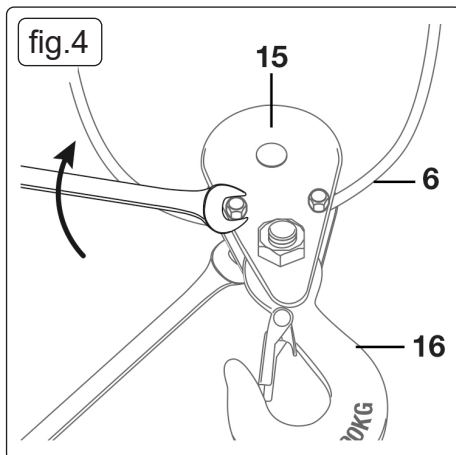

8. OPERATION

NOTE: Numbers refer to features diagram.

- 8.1. Remove the adhesive tape from the drum (3) before using the hoist for the first time.
- 8.2. The value of the A-rated noise emissions at the operator's position is less than 70 dB.
- 8.3. Supply voltage: 230 V ± 10%, 50 Hz ± 1%.
- 8.4. The cable hoist must be operated in ambient temperatures of between 5°C and 40°C with a relative humidity of less than 90%. Height above sea level: max. 1,000 m.
- 8.5. The temperature for transport and storage may be between -25°C and 55°C. The maximum temperature must not exceed 70°C.
- 8.6. The user should lift the load off the ground at the slowest possible speed. The cable should be taut when the load is raised.
- 8.7. The motor (14) for the cable hoist is fitted with a thermostat switch. Whilst the cable hoist is operating, the motor (14) may therefore stop. It will restart automatically when it has cooled down.
- 8.8. Hoist is not fitted with a rated power limiter. You should therefore not repeat attempts to lift a load if the overload trip is limiting the hoist's operation. In this case the load exceeds the rated capacity of the cable hoist.

* **DO NOT** leave any suspended loads unsupervised without first taking the appropriate safety precautions.

8.9. Fit the machine with a 10 A fuse or a 10 A residual current operated circuit breaker (RCCB) to protect the circuit.
× **DO NOT** use the lever (4/5) as a routine stopping device. It should only be used to stop the machine in an emergency.

8.10. Before you start, ensure that the steel cable (6) is correctly wound around the drum (3) and that the spacing between the winds is smaller than the steel cable, fig.8.

8.11. Ensure that the load is correctly secured to the hook (8) or, if you are using the block and tackle, the additional hook (16) and always maintain a safe distance from the load and the steel cable (6).

8.12. (16) and always maintain a safe distance from the load and the steel cable (6).

8.13. OPERATION

Check whether the Emergency Stop switch (9) is pressed. Turn the red stop switch clockwise to release it.

Press the pushbutton ▲ (10) to raise the load.

Press the pushbutton ▼ (10) to lower the load.

Automatic stop mechanism lever (5): When the maximum lifting height has been reached, the cut-out weight (7) presses the lever (5) upwards.

This trips a limit switch after which the load cannot be raised any further. Lever for maximum cable length (4): When the load has reached its lowest possible position, a limit switch is tripped which makes it impossible to lower the load any further.

This limit switch also prevents the cable hoist operating in the wrong direction (hook moving in the opposite direction to the arrow shown on the control switch).

The cable hoist will stop if the Emergency Stop switch (9) is pressed.

8.14. EMERGENCY STOP

In an emergency, immediately press the Emergency Stop switch (9) to stop the cable hoist. The cable hoist cannot be operated if the Emergency Stop switch has been pressed.

8.15. INTERMITTENT RATING

This machine is designed for operating type S3 20% - 10 min (periodic intermittent operation).

The relative duty cycle is 20%, which means that the device can be operated at rated load for 2 minutes during each operating cycle and must then be switched off for 8 minutes to cool off. The device can therefore be continuously used for a duration of 20% of the total operating cycle of 10 minutes at rated load.

8.16. OVERLOAD

A) The cable winch is not suitable for continuous operation. The motor is protected from overload and overheating by a temperature switch.

B) If the permissible operating time is exceeded, the motor temperature will increase and the temperature switch will shut the cable winch off. The temperature switch will automatically switch back on after a cooling phase.

C) In case of a strain on the cable hoist with a lesser load, the operating time will increase and the cooling time will decrease.

D) **NOTE:** In case of direct exposure to sunlight, the temperature of the casing will increase significantly, which will also decrease the permissible operating time. It is therefore possible that the temperature switch will switch off after a short time period and the cable winch will shut down. Please wait until the device has cooled off.

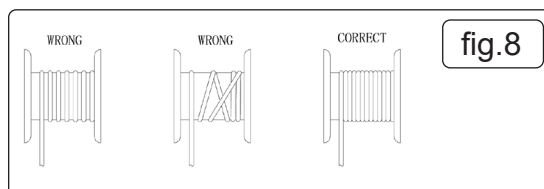

9. MAINTENANCE

❑ **WARNING!** Remove from mains supply before performing any Maintenance or Cleaning.

9.1. CLEANING

Keep all safety devices, air vents and the motor housing free of dirt and dust as far as possible.

Wipe the equipment with a clean cloth or blow it with compressed air at low pressure.

Clean the device immediately each time you have finished using it. Clean the equipment regularly with a moist cloth and some soft soap. **DO NOT** use cleaning agents or solvents; these could attack the plastic parts of the equipment. Ensure that no water can seep into the device.

9.2. MAINTENANCE

A check must be made every 30 cycles, or below showing, to find whether the entire steel cable (6) is in good condition. If it is damaged, it must be replaced by a steel cable of the type specified in the technical data.

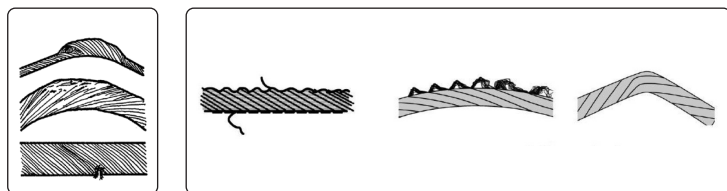

During assembly of the cable, it is imperative to remember the Cut-out weight (7) in order to ensure a secure limit stop.

9.3. SERVICING

Provide enough clearance around the 400 kg power hoist (230v/1ph) for safe access to all components during inspection and maintenance.

❑ **WARNING!** Always ensure that the machine is not connected to the mains supply before starting any servicing work. In the following: One cycle means one raising and lowering movement of a load. Periodic inspection means an inspection after 100 cycles.

9.3.1. Test periodically that the limit switches on the cable hoist are in correct working order.

Conduct this test as follows: When the cable has reached the maximum height, the lever on the automatic stopping mechanism (5) will be actuated. The motor (14) must then stop. (Test without a load).

When the steel cable (6) has been unwound as far as possible, the lever for the maximum cable length (4) will be actuated. The motor (14) must then stop.

9.3.2. Inspect the mains cable (12) and the control cable (13) periodically.

9.3.3. The steel cable (6) and return roller (15) must be greased every 200 cycles.

9.3.4. Check every 1000 cycles whether the screws for the fastening clamps (1) and return roller (15) are properly tightened.

9.3.5. Check every 1000 cycles whether the hooks (8/16) and return roller (15) are in good condition.

- 9.3.6. Check before using the cable hoist whether the Emergency Stop switch (9) and push buttons (10) are in perfect working order.
- 9.3.7. Check the braking system every 1000 cycles. If the motor (14) makes any unusual noises or cannot raise the rated load, it is possible that the braking system requires an overhaul:
- Replace damaged or worn parts and keep the service documentation relating to this in a safe place.
- 9.3.8. Please contact an authorized service centre for any unscheduled maintenance work.
- 9.4. PREVENTATIVE MAINTENANCE MEASURES TO BE OBSERVED**
Preventative maintenance for the 400 kg Power Hoist (230V/1PH) includes routine inspection of the wire rope or chain, hooks, and safety latches for wear or damage. Check the motor, brake, limit switches, and control pendant for proper operation, and ensure all electrical connections are secure. Keep the unit clean, properly lubricated, and follow a regular maintenance schedule to ensure safe and reliable performance.
- 9.5. CHECKING THE FUNCTION OF THE LIMITER**
Run the hoist without load and confirm it stops automatically at the upper and lower travel limits. Ensure the limit switch cuts off power smoothly without overrun. Repair any faults immediately to prevent damage or safety risks.
- 9.6. RESTARTING THE MACHINE AFTER AN INTERVENTION**
After maintenance on the 400 kg Power Hoist (230V/1PH), ensure all parts and safety devices are secure, restore power, and perform a no-load test run before normal operation.
- 9.7. FAULT IDENTIFICATION AND LOCATION FOR REPAIR**
Check the 400 kg Power Hoist (230V/1PH) for unusual noises, vibrations, or movement. Inspect the motor, brakes, limit switches, electrical connections, and load chain or rope to locate and repair faulty components.
- 9.8. STORAGE**
Store the equipment and accessories out of children's reach in a dark and dry place at above freezing temperature. The ideal storage temperature is between 5 and 30 °C. Store the electric tool in its original packaging.
- 9.9. TRANSPORT**
Transport in original packaging to protect from damage. Secure when being transported in vehicles to prevent damage. Centre of gravity of the hoist will be biased towards the motor end.
- 9.10. SPARE PART SPECIFICATION**
The 400 kg Power Hoist 230V/1PH requires spare parts that are specifically designed for single-phase, 230-volt electric hoists with a 400 kg lifting capacity. Key components typically include the motor, gearbox, limit switches, brake assembly, control pendant, and load chain or wire rope. All replacement parts should meet the original manufacturer's specifications to ensure safe and reliable operation, maintain lifting efficiency, and comply with electrical and mechanical standards. Proper installation and regular inspection of these parts are essential for optimal hoist performance and longevity.

10. TROUBLESHOOTING

Problem	Cause	Solution
The Off/On switch is used but the motor does not turn	<ol style="list-style-type: none"> 1. It is not plugged into the power supply. 2. The wires are broken or ripped. 3. Switch Malfunction 4. The capacitor is burned through. 5. End-switch has not been reset or a limit switch error 6. The thermal switch has suffered a wire break. 	<ol style="list-style-type: none"> 1. Connect the item to the power supply. 2. Check the wires and plug it in again to the outlet. 3. Repair switch or change it 4. Change your capacitor 5. Check the end-switch and replace the limit switch. 6. Wait until the item cools down, or replace the thermal switch.
The dual-direction switch has been activated. The motor is very loud, can however not pick-up the load.	<ol style="list-style-type: none"> 1. The voltage supply is too low. 2. The capacitor has become damaged. 3. The brake is not completely open. 	<ol style="list-style-type: none"> 1. Adjust the work, depending on the power supply. 2. Change power supply. 3. Allow the machine to be repaired by a qualified repair service.
After a power outage the brakes do not hold or the machine slips down.	<p>The gap between the brakes is too large.</p> <p>The brake spring is ripped.</p> <p>The brake disk is locked .</p> <p>The brake disk is at the start is already dirty.</p>	Qualified repair.
The sound of the motor Becomes louder	<ol style="list-style-type: none"> 1. Lack of lubrication. 2. After a long use, the cogwheel and bearings are damaged. 3. Badly installed or damaged. 	<ol style="list-style-type: none"> 1. Oil/Grease machine. 2. Change the cogwheel or bearings. 3. Check installed parts.
Over supply of voltage.	<ol style="list-style-type: none"> 1. Earth error or not earthed. 2. The internal connectors are touching the housing 	<ol style="list-style-type: none"> 1. Checked earth wires and properly connect them. 2. Check all internal connections
End-switch is not functioning.	<ol style="list-style-type: none"> 1. The end-switch is defective 2. End-switch is faulty. 	<ol style="list-style-type: none"> 1. Replace. 2. Check, repair, and replace end switch

11. END OF SERVICE

When a lifting hoist reaches the end of its service life, it must be safely decommissioned and disposed of to prevent accidents, ensure compliance with safety regulations, and avoid unauthorized use.

A hoist should be taken out of service if it: 1. Fails safety inspections or load tests. 2. Has excessive wear , cracks, or deformation in key load-bearing components. 3. Has repeated failures despite regular repairs and maintenance. 4. Exceeds its manufacturer-defined service life. 5. Has obsolete or unavailable replacement parts.

Once a hoist is deemed unfit for use, it must not be operated again.

12. END OF LIFE

Dismantle and recycle according to regulations in force at the end of product's working life.



ENVIRONMENT PROTECTION

Recycle unwanted materials instead of disposing of them as waste. All tools, accessories and packaging should be sorted, taken to a recycling centre and disposed of in a manner which is compatible with the environment. When the product becomes completely unserviceable and requires disposal, drain any fluids (if applicable) into approved containers and dispose of the product and fluids according to local regulations.



REGISTER YOUR
PURCHASE HERE



WEEE REGULATIONS

Dispose of this product at the end of its working life in compliance with the EU Directive on Waste Electrical and Electronic Equipment (WEEE). When the product is no longer required, it must be disposed of in an environmentally protective way. Contact your local solid waste authority for recycling information.

Note: It is our policy to continually improve products and as such we reserve the right to alter data, specifications and component parts without prior notice. Please note that other versions of this product are available. If you require documentation for alternative versions, please email or call our technical team on technical@sealey.co.uk or 01284 757505.

Important: No Liability is accepted for incorrect use of this product.

Warranty: Guarantee is 12 months from purchase date, proof of which is required for any claim.

Jack Sealey Ltd t/a Sealey Group, Kempson Way, Suffolk Business Park, Bury St Edmunds, Suffolk, IP32 7AR UK
Jack Sealey (EU) Ltd t/a Sealey Group, Farney Street, Carrickmacross, Co. Monaghan, A81 PK68 Ireland
Tel: 01284 757500 • **Email:** sales@sealey.co.uk • **Web:** www.sealey.co.uk